

Common Sensor Node development Collaboration with NECTEC (Thailand)

Nobuyuki Asai
NICT Asia Center @Bangkok
Contact: asai@nict.go.jp

There are many IVO projects on IoT.

The subject of research is AI, Analyzing data, considering for optimization and it may be security etc.

	Number of total Project	Number of project on IoT	Need for sensor data
2016 Project	8	2	1
2017 Project	5	4	1
2018 Project	6	5	4
2019 Project	5	3	2



We considered providing a general-purpose board to collect sensor data. If we provide it to projects whose research is not primarily data collection, can it be cost reduction? Can it be saving time?

Our discussion is to develop common board that is:

- (1) Ras Pi (CM3) carrier board to connect several sensor as standard board
- (2) Charge controller board that can run continuously and stability

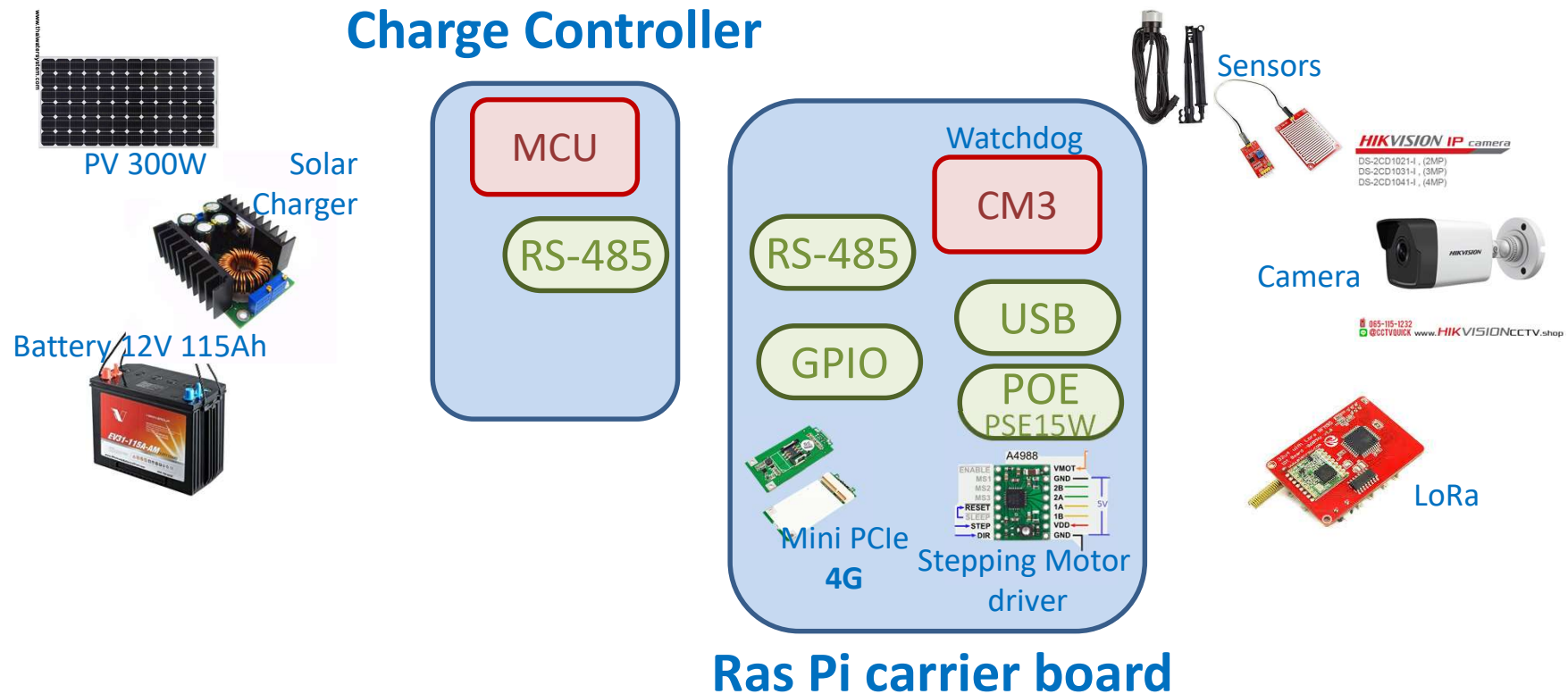

Example of requirement for Visual IoT

Solar Battery & Car Battery 12V /24V

Dual LAN ports: one for IP camera (PoE: PSE support, min.15W) and the other for the Internet
 LTE (4G) for the Internet

Optional

- Wake up triggered by external sensors (interface unknown: UART, I2C, RS485, RS422, USB, BLE...)
- Control of external "Stepping Motor"
- USB (one port at least): for USB camera

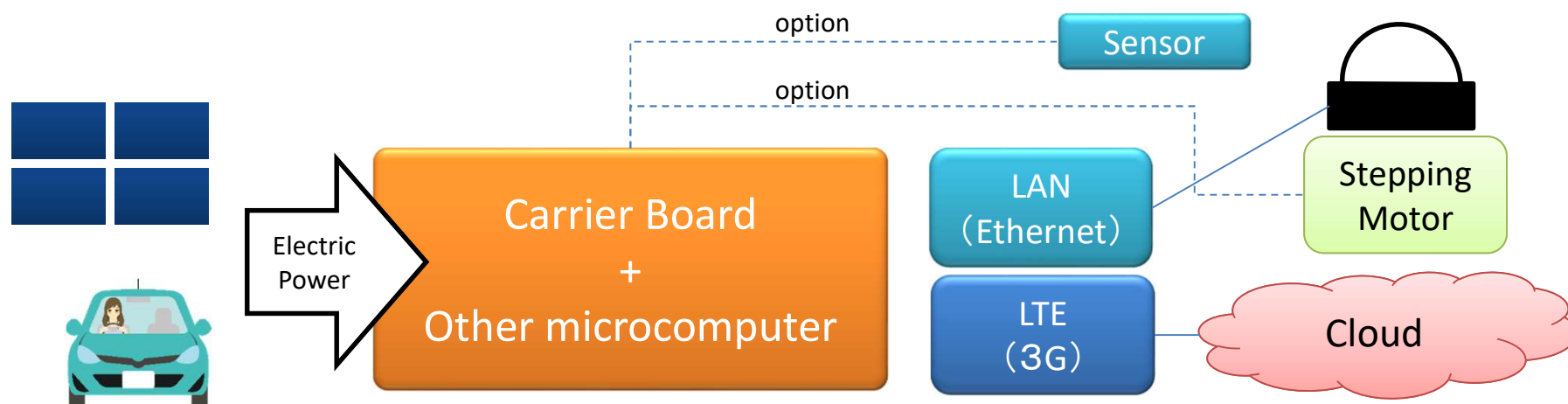



Example of Specification for Visual IoT

1. Solar PV = 300W, Size 2x1 meter (maximum), usually using 100W
2. Battery = 12V, 115AH (sealed or semi-sealed lead acid)
3. LTE (4G) for the Internet: miniPCIe for LTE module <USB signal only>
4. WatchDog = using MCU (original & configurable via I2C)
selectable by DIPsw : keep alive signal pin (RPI GPIO)
5. Print Circuit Board Layer (PCB Layer): number of layer is 4 or 2.
Requires IP camera power control circuit for Power ON Reset
6. Case size = W:130mm H:180mm D:80mm (minimal target)
e.g. TAKACHI BCAP131808G, BCPC162113S
7. Board size = 100mm x 100mm or less
e.g. TAKACHI BMP1217P, BMP1520P

Block Diagram of Ras PI Carrier Board

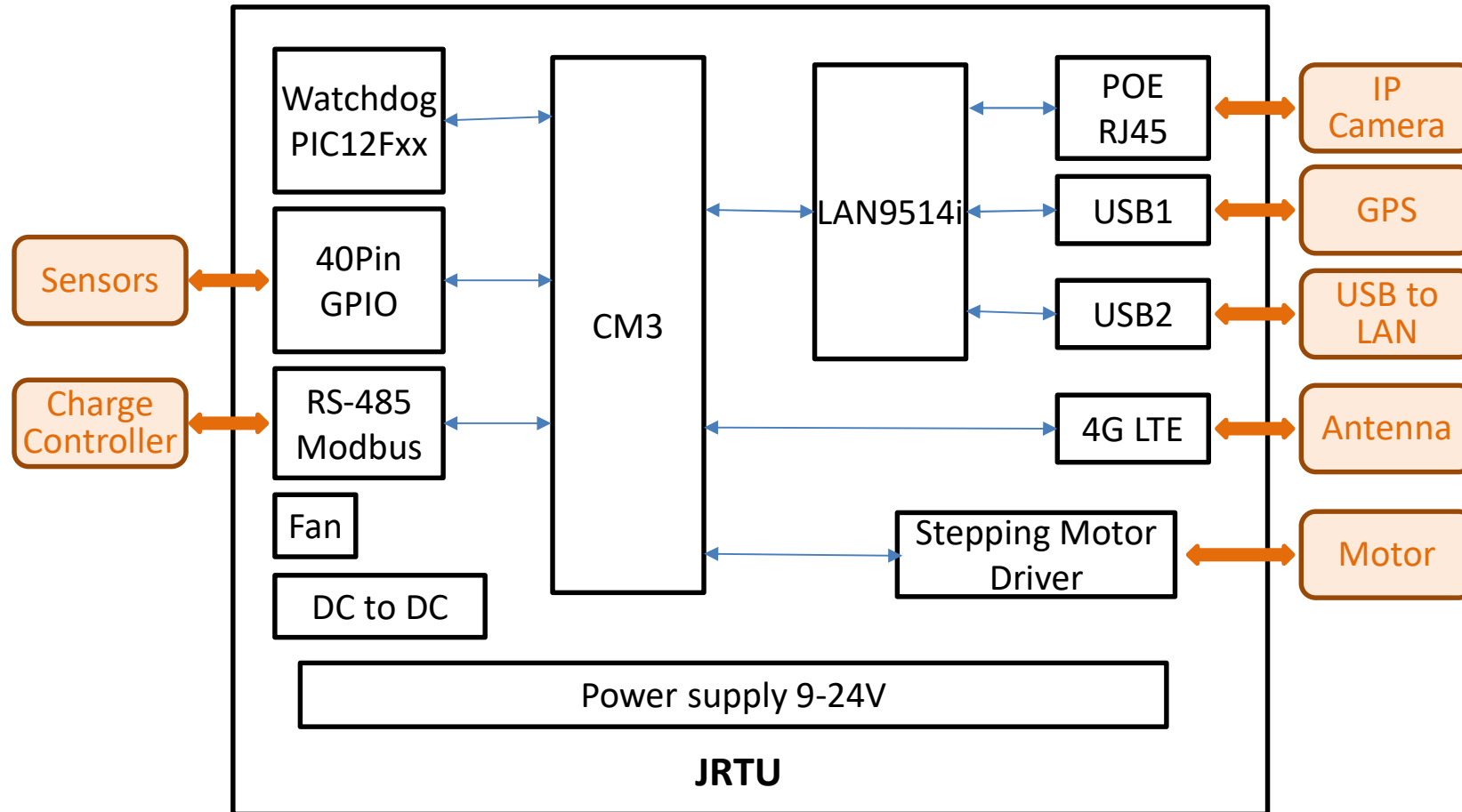

If some IVO project is not focus to sensor just collect data and its focus is higher level experiment such as Data analysis, AI etc.:

NICT Asia Center will rent the equipment.

At first NICT Asia Center will make the 10 set of equipment.

Objective is to reduce time consumption, cost ...:

- To be common tool for field test**
- Robust for indoor and outdoor**
- Stable power supply**
- Running for long time experiment**

**Board development is supported by NECTEC.
Thanks for NECTEC cooperation.**